

### 可選配置 Optional Configuration

電源要求	Power Requirements	380V/50HZ/3P	380V/50HZ/3P
加熱方式	Heating	電 Electricity	蒸汽 Steam
進水溫度 (°C)	Incoming Water temperature (°C)	10—60	10—60
水槽加熱功率 (千瓦)	Tank heater (KW)	7.5x2	-
漂洗加熱功率 (千瓦)	Booster heater (KW)	18x2	-
蒸汽總耗量 (公斤/小時)	Total steam consumption (Kg/h)	-	88
清洗水泵功率 (千瓦)	Wash pump (KW)	1.5x2	1.5x2
傳動馬達功率 (千瓦)	Drive motor (Kw)	0.2	0.2
總功率 (千瓦)	Total connected load (KW)	55	4
總電流 (安培)	Total amps required (A)	84	6
電源線截面 (mm <sup>2</sup> )	Cross section of cable (mm <sup>2</sup> )	25	2.5
空氣開關額定電流 (安培)	Rated current of circuit breaker (A)	100	16

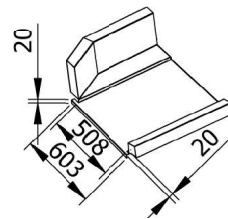

- (1) 進水管連接 Water In
- (2) 排水連接 Drain Out
- (3) 電源連接 Cable Connection

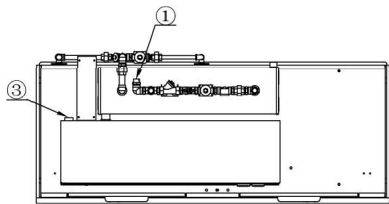
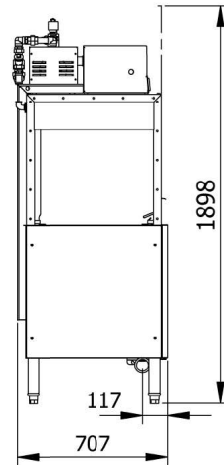
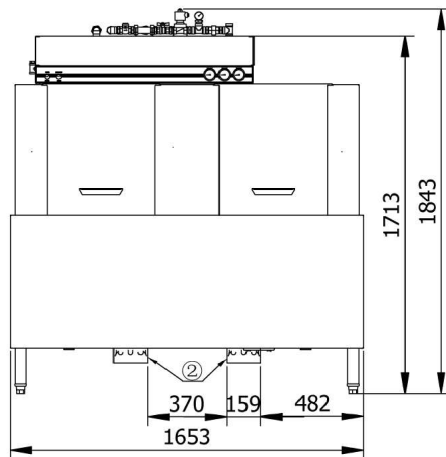

### 特點及優勢 Characteristics and Advantages:

- 不銹鋼清洗泵，經久耐用，功率強大，確保洗滌效果
- 所有配件都易於拆裝清洗，不需任何輔助工具
- 安全保護裝置，無人取碗時會自動停機，進一步降低運行成本
- 一體式上罩設計，防止水濺出並可在安裝過程中更改機器方向
- 多種適用範圍，熱水和冷水均可使用

- Long lasting operation as all components are made of stainless steel 304
- All internal components are easy to remove and clean
- Auto start/stop levers further reduce water and energy consumption
- Integrated splash hood avoids splash and makes it easy to switch direction during installation
- Various range suitable to both hot and cold main water supply temperature

## 安裝接駁要求 Installation and Connection Requirements

電力安裝需要380V/50Hz三相五線,外部需加裝獨立的空氣開關

洗滌流程中需要另配排風罩、汗碟台、花灑龍頭、杯筐、藥液分配器、機用清潔劑和催乾劑等

機器可直接與一般供水系統連接,最低水壓須達到2Kg/cm<sup>2</sup>

如需安裝排氣罩,排氣量為入口端—5.7 m<sup>3</sup>/min,出口端—11.3 m<sup>3</sup>/min

Power requirements: 380V/60Hz/3N + Neutral + Ground, with an external circuit breaker.

In the washing process, additional exhaust hood, working tables, baskets, liquid medicine dispensers, machine used detergents and rinse aid are needed to be equipped.

Machine can be directly connected to water supply system, the lowest incoming water pressure should be 2Kg/cm<sup>2</sup>

If a hood or vent needed, the inlet capacity should be 5.7m<sup>3</sup>/min and the outlet 11.3 m<sup>3</sup>/min

## 技術參數 Technical Data

名稱/型號	Name/Model	ORT200ER/ORT200SR	ORT300ER/ORT300SR
加熱方式	Heating	電Electricity/蒸汽Steam	電Electricity/蒸汽Steam
外形尺寸(毫米)	Appearance dimension (mm)	1148×706×1840	1653×706×1840
機器入口寬度(毫米)	Passing width (mm)	508	508
最大洗滌高度(毫米)	Max clear entry height (mm)	450	450
最大洗滌量(筐/小時)	Max capacity (rack/hour)	200	250
耗水量(升/筐)	Water consumption (L/rack)	2	1.5
水箱容積(升)	Wash tank capacity (L)	90	90x2
升溫器容積(升)	Booster capacity (L)	20.8	20.8
洗滌溫度(°C)	Wash temperature (°C)	60~65	60~65
漂洗溫度(°C)	Rinse temperature (°C)	82~90	82~90
進水管徑(英寸)	Diameter of water inlet hose (in)	3/4	3/4
排水管徑(英寸)	Diameter of drainpipe (in)	2	2
進水壓力(千克/平方釐米)	Incoming water pressure (kg/cm <sup>2</sup> )	2-5	2-5
進水硬度(克/升)	Incoming water hardness (g/L)	0.034-0.103	0.034-0.103



## 可選配置 Optional Configuration

電源要求	Power Requirements	380V/50Hz/3P	380V/50Hz/3P
加熱方式	Heating	電Electricity	蒸汽Steam
進水溫度(°C)	Incoming Water temperature (°C)	10—60	10—60
水槽加熱功率(千瓦)	Tank heater (KW)	7.5	-
漂洗加熱功率(千瓦)	Booster heater (KW)	18x2	-
蒸汽總耗量(公斤/小時)	Total steam consumption (Kg/h)	-	75
清洗水泵功率(千瓦)	Wash pump (KW)	1.5	1.5
傳動馬達功率(千瓦)	Drive motor (Kw)	0.2	0.2
總功率(千瓦)	Total connected load (KW)	46	2.5
總電流(安培)	Total amps required (A)	70	3.8
電源線截面(mm <sup>2</sup> )	Cross section of cable (mm <sup>2</sup> )	25	2.5
空氣開關額定電流(安培)	Rated current of circuit breaker (A)	100	16

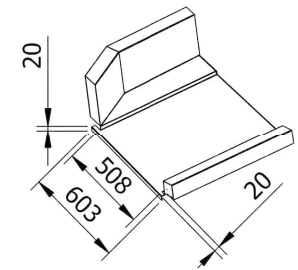
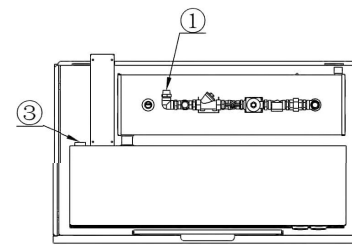
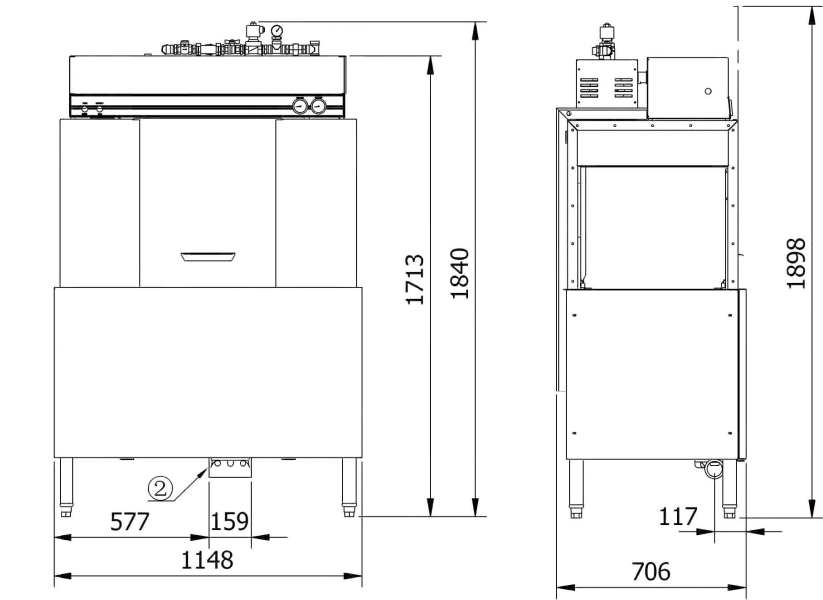

- (1) 進水管連接 Water In
- (2) 排水連接 Drain Out
- (3) 電源連接 Cable Connection